



March 3-7



Ski Jumping & Nordic Combined
2015 JUNIOR NATIONALS
Steamboat Springs, Colorado





December 1, 2014

Dear Coaches, Officials and Competitors,

We are hosting the 2015 Ski Jumping and Nordic Combined Junior Nationals in Steamboat Springs, CO on March 3-7, 2015. The following information is our Schedule of Events and some lodging/meal options for your team's stay.

On behalf of Steamboat Springs Winter Sports Club (SSWSC) and the Rocky Mountain Division SJ/NC Junior Nationals Organizing Committee, we invite you to join us in Steamboat, Colorado in March 2015 for another great Junior National competition. All the events will take place at Howelsen Hill, 845 Howelsen Parkway, in Steamboat, CO, 80487.

If you have any direct questions about the competition, please contact Kris Rowse at rowses2002@yahoo.com. If you have any questions about lodging, meal plans, or athlete/parent events, please contact Laura Sankey at L2Sankey@hotmail.com. If you have any official or judging questions, please direct your questions to Larry Glueck, Chief of Competition at larsglueck@cs.com.

The Competition Secretary is Tonya Dean. Please contact her at tkaydean@gmail.com. The entry fee per competitor is \$200. Entry information will be posted on the website on February 1, 2015. Entries will be due on February 17, 2015.

Please visit our website at <http://www.jncjn2015.com/> for the most up to date information.

Sincerely,

Todd

Todd Wilson
SSWSC NC/SJ Director

Laura

Laura Sankey
2015 JN Co-Chair

Kris

Kris Rowse
2015 JN Co-Chair



**2015 SKI JUMPING AND NORDIC COMBINED JUNIOR OLYMPICS
Schedule of Events**

Tuesday, March 3rd

10:00AM – 12:00PM	Open Training HS75
1:00PM – 5:00 PM	Competition Headquarters Opens – Registration, Olympian Hall
2:00PM – 4:00 PM	Open Training HS75
6:00PM	Team Captains' Meeting and Draw – (Location TBD)
7:15PM	Opening Ceremonies – (Details to follow)
8:00PM	Cookie Celebration – Olympian Hall

Wednesday, March 4th

7:30AM	Equipment Compliance – Olympian Hall
10:00 AM - 1:00 PM	HS75 Official Training (3 Rounds)
2:30 PM - 4:00 PM	Cross Country Official Training
6:00PM	Team Captains' Meeting – Olympian Hall
6:30PM	Athlete Fun Event - Tubing

Thursday, March 5th

NORDIC COMBINED & SPECIAL JUMPING INDIVIDUAL EVENTS – HS75

8:00AM	Bib Pick up
9:00AM - 9:45 AM	Trial Jump
9:50 AM	National Anthem and Fore Jumpers
10:00 AM- 10:45 AM	1 st Round Jump
11:00 AM- end	2 nd Round Jump
Immediately following	Podium Ceremony – Bottom of Jumps

NORDIC COMBINED – INDIVIDUAL GUNDERSEN EVENTS – 5KM

3:00 PM	Cross Country Race – Romick Rodeo Arena
Immediately Thereafter	Podium Ceremony – Romick Rodeo Arena
6:00 PM	Team Captains' Meeting – Olympian Hall

Friday, March 6th

NORDIC COMBINED & SPECIAL JUMPING TEAM EVENTS – HS75

9:00AM	Bib Pick-up
10:00 AM – 10:45 AM	Trial Jump
10:50 AM	National Anthem and Fore Jumpers
11:00 AM – 11:45AM	1 st Round
12:00PM – End	2 nd Round
Immediately following	Podium Ceremony – Bottom of Jumps
2:00PM or immediately following	Team Captain's Meeting

NORDIC COMBINED TEAM SPRINT – 2 X 3KM

6:00pm	Cross Country Team Relay Races – Romick Rodeo Arena
Immediately Thereafter	Podium Ceremony & Team Photos – Romick Rodeo Arena
7:30PM	USSA Junior Committee Meeting – Olympian Hall

Saturday, March 7th

ELIMINATION JUMP – HS75

9:00 AM	Bib Pick-up
10:00 AM – 10:45 AM	Trial Jump
10:50 AM	National Anthem and Fore Jumpers
11:00 AM – End	Elimination Jump Competition
Immediately following	Podium Ceremony – Bottom of Jumps
5:00PM	Awards Banquet



GETTING HERE

Getting to Steamboat is easy, whether you're flying or driving. Steamboat Springs has the closest major airport (HDN) of any ski resort in Colorado, located just 22 miles away in Hayden with daily jet air service year round.

Steamboat is also a scenic three hour (157 miles) drive from Denver, Colorado (DIA).

LODGING

We worked with Wyndham Vacation rentals, a partner of the Winter Sports Club, to set up special lodging rates for the J/NC Junior Nationals athletes and families at 2 premier condo properties.

	Rate/Night*	# of Beds/Condo (not including Sofa Sleeper)**	# of Beds/Condo (including Sofa Sleeper)	\$/Person w/o S.S.	\$/Person w/ S.S.
The Lodge					
1 Bedroom/1 Bath	\$216	2	3	\$108	\$72
2 Bedroom/2 Bath	\$240	3	4	\$80	\$60
3 Bedroom/3 Bath	\$320	4	5	\$80	\$64
Canyon Creek					
2 Bedroom/2 Bath	\$248	3	4	\$83	\$62
3 Bedroom/3 Bath	\$333	4	5	\$83	\$67
4 Bedroom/3 Bath	\$405	5	6	\$81	\$68

*rates do not include 18.91% sales tax and resort fees

**each unit has 2 twin beds in one of the bedrooms, so that each athlete can have their own bed

THE LODGE <http://www.wyndhamvacationrentals.com/vacation-rentals/colorado/steamboat-springs/steamboat-springs/complex/lodge-at-steamboat>

CANYON CREEK <http://www.wyndhamvacationrentals.com/vacation-rentals/colorado/steamboat-springs/steamboat-springs/complex/canyon-creek>

We strongly recommend that you reserve units as soon as possible, as competition dates coincide with the start of spring break vacations. Because of our special relationship with Wyndham and the dates for qualification, cancellations with no penalty will be accepted with 35 days notice.

In addition to special rates and cancellations policy – there will also be dedicated locations for wax facilities

- Wax facility locations will be an indoor garage at Canyon Creek; and an exposed, but covered, garage at The Lodge. We are hoping that all teams will take advantage of these properties, and respect that only guests at a respective property will be able to use wax facilities at that location.

These properties are a 5-minute drive from Howelsen Hill and downtown Steamboat Springs.

For booking, please contact Carter Allen at (970) 871-4445 and identify that you are calling about the “2015 Jump/Nordic Combined Junior Nationals.”



MEAL OPTIONS

With the ease of making breakfasts and lunches (including prepping sack lunches) in the condos, we are assuming most teams will choose to make those meals on their own.

There are many options for meals while you are here in Steamboat. In addition to prepping and eating meals in your condo, we have secured a meal plan option at Colorado Mountain College, which is very close to Howelsen Hill where the competition takes place. They offer a full, hot buffet (all you can eat) that provides great nutrition for athletes and coaches at a very reasonable price.

Pricing for meals at the dining hall:

Breakfast \$5.75

Lunch \$7.15

Dinner \$8.55

The CMC kitchen can also provide bagged lunches, which include: Sandwich, Chips, Fruit, Small Cold Salad, Cookie, & Bottled Water for \$9.95

In order for the kitchen to plan for the additional meals for the J/NC teams, we ask that teams sign up for a meal plan by February 1, 2015. You may customize your plan by selecting meals for each day.

Please contact Laura Sankey at L2Sankey@hotmail.com to sign up your team for the meal plan. Please include JNC MEAL PLAN as your subject line.





FÉDÉRATION INTERNATIONALE DE SKI
INTERNATIONAL SKI FEDERATION
INTERNATIONALER SKI - VERBAND



No. 355 / USA 21

CERTIFICATE OF JUMPING HILL
CERTIFICAT DE CONFORMITE
SCHANZENPROFILBESTÄTIGUNG

Date of issue 25.01.2007
Établi le
Ausgestellt am

Valid till 31.12.2011
Valable jusqu' au
Gültig bis

Place: Steamboat Springs

Name: Howelsen Hill

HS = 75 m h/n 0.52

Vo = 22m/s

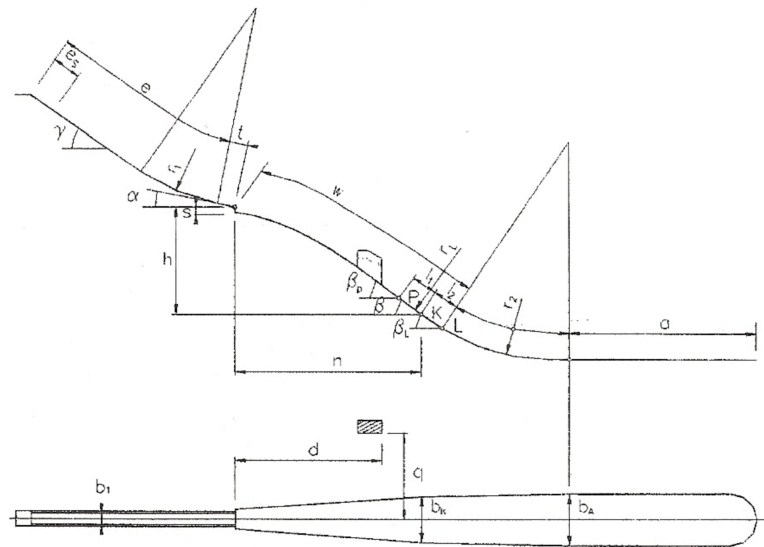

$e = 77.38$ m
 $e_s = 18.78$ m
 $t = 5.75$ m
 $\gamma = 34^\circ$
 $\alpha = 10.0^\circ$
 $r_1 = 74$ m
 $h = 31.26$ m
 $n = 60.31$ m
 $s = 1.7$ m

$l_1 = 7.14$ m
 $l_2 = 7.14$ m
 $a = 100$ m
 $\beta_p = 35.62^\circ$
 $\beta = 33^\circ$
 $\beta_L = 30.38^\circ$
 $r_L = 156$ m
 $r_2 = 80$ m

$P = 60.86$ m
 $K = 68$ m
 $L = 75.14$ m
 $b_1 = 2.5$ m
 $b_k = 13.6$ m
 $b_A = 14.96$ m
 $d =$ m
 $q =$ m

Remarks/Remarques/Bemerkungen:

JUMPING HILL APPROVED BY THE FIS
TREPLIN HOMOLOGUE PAR LA FIS
DURCH DIE FIS GENEHMIGTE SPRUNGSCHANZE

SUB-COMMITTEE FOR JUMPING HILLS

